

LOADS		TENSION[kN]
BREAKING LOAD	BL	100
PROOF LOAD	PL	63
SAVE WORKING LOAD	SWL	50

WEIGHT: 3,35 kg

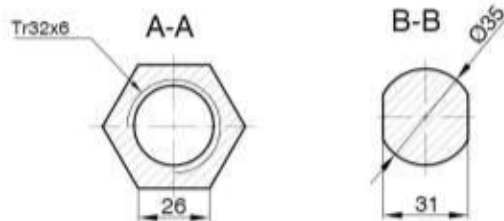
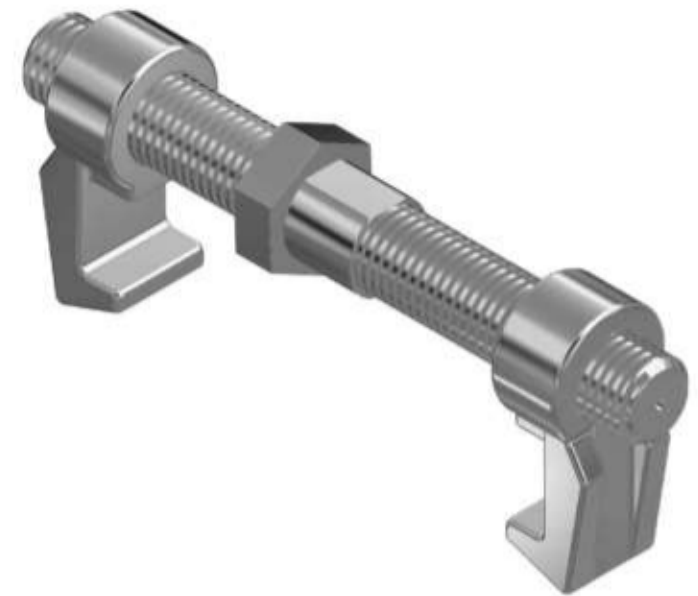

Artikel-Nr.: SQS_CLE10-05-0002-00

Container Bridge Fitting (large)

SQS UG (haftungsbeschränkt)
Talstraße 13
71546 Aspach

Fon: +49 7191 7351-300
Fax: +49 7191 7351-399
kontakt@sqs-shop.de

SQS[®]
Safety Quality System