

| LOADS | | TENSION[kN] |
|-------------------|-----|-------------|
| BREAKING LOAD | BL | 100 |
| PROOF LOAD | PL | 63 |
| SAVE WORKING LOAD | SWL | 50 |

WEIGHT: 2,8 kg

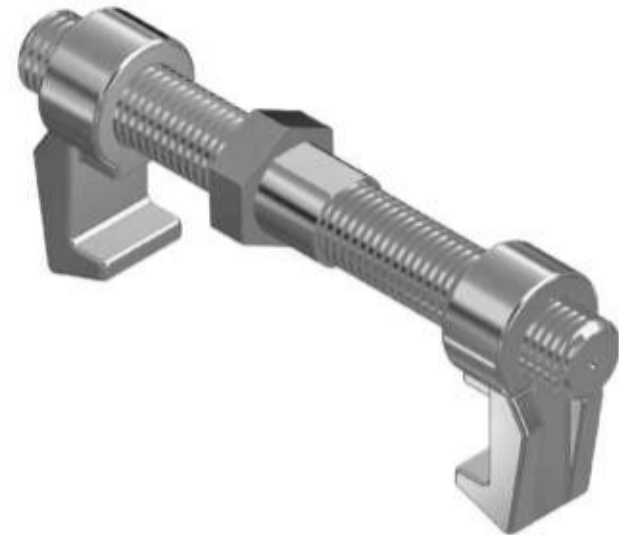

Artikel-Nr.: SQS_CLE10-05-0001-00

Container Bridge Fitting (small)

SQS UG (haftungsbeschränkt)
Talstraße 13
71546 Aspach

Fon: +49 7191 7351-300
Fax: +49 7191 7351-399
kontakt@sqshop.de

SQS[®]
Safety Quality System